

# 6.01 Midterm 2

Spring 2018

**Name:**

**Kerberos (Athena) name:**

**Please WAIT until we tell you to begin.**

During the exam, you may refer to any written or printed paper material.  
**You may NOT use any electronic devices (including calculators, phones, etc).**

If you have questions, please **come to us at the front** to ask them.

**Enter all answers in the boxes provided.**

Extra work may be taken into account when assigning partial credit,  
but only work on pages with QR codes will be considered.

**Question 1:** 16 Points

**Question 2:** 16 Points

**Question 3:** 16 Points

**Question 4:** 16 Points

**Question 5:** 24 Points

**Total:** 88 Points

## 1 Party Lights (16 Points)

In order to get ready for a party, you decide to decorate your dorm room with some festive lights. When you get to the store, you notice that they have three different varieties of bulb packages, each of which can be wired together in two different ways:

In package A, each bulb stands on its own. In package B, each bulb is wired in series with a resistor with a fixed, finite, non-zero resistance  $R$ . In package C, each bulb is wired in parallel with a resistor with a fixed, finite, non-zero resistance  $R$ .

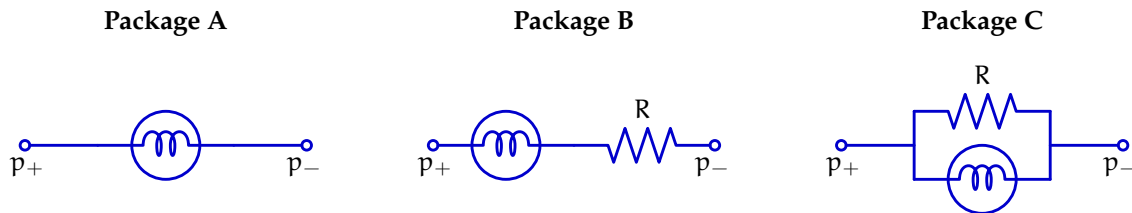

In wiring mode i, all of the bulb packagings are connected in series. In wiring mode ii, all of the bulb packagings are connected in parallel.

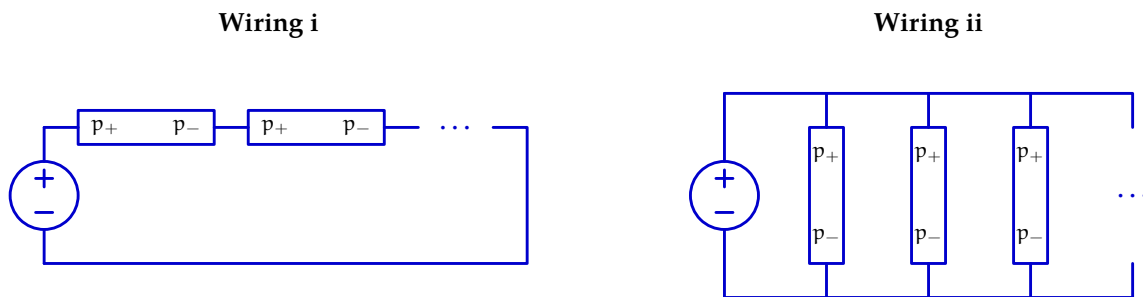

Ideally, you would like your lights to be robust against two different kinds of failure:

- *Burning out:* the bulb burns out, so that no current can flow through it anymore.
- *Shorting:* the two contacts of the bulb are bent so they touch and current flows through the bulb as though it were a wire.

Model each functioning bulb as a resistor with a fixed, finite, non-zero resistance; its brightness is proportional to the current flowing through it (regardless of the direction of current flow). For each of the questions below, your answer should be one of the following:

- The bulbs get brighter
- The the bulbs remain the same brightness
- The bulbs get dimmer but remain on
- The bulbs go out completely
- Some bulbs get brighter and some get dimmer
- The answer depends on the particular value of  $R$

**1.1 Package A, Wiring i**

In this setup, what happens to the other bulbs when the first bulb burns out?

In this setup, what happens to the other bulbs when the first bulb is shorted?

In this setup, what happens to the original bulbs when an additional bulb is added?

**1.2 Package A, Wiring ii**

In this setup, what happens to the other bulbs when the first bulb burns out?

In this setup, what happens to the original bulbs when an additional bulb is added?

**1.3 Package B, Wiring i**

In this setup, what happens to the other bulbs when the first bulb burns out?

In this setup, what happens to the other bulbs when the first bulb is shorted?

In this setup, what happens to the original bulbs when an additional bulb is added?

**1.4 Package B, Wiring ii**

In this setup, what happens to the other bulbs when the first bulb burns out?

In this setup, what happens to the other bulbs when the first bulb is shorted?

In this setup, what happens to the original bulbs when an additional bulb is added?

**1.5 Package C, Wiring i**

In this setup, what happens to the other bulbs when the first bulb burns out?

In this setup, what happens to the other bulbs when the first bulb is shorted?

In this setup, what happens to the original bulbs when an additional bulb is added?

**1.6 Package C, Wiring ii**

In this setup, what happens to the other bulbs when the first bulb burns out?

In this setup, what happens to the original bulbs when an additional bulb is added?

## 2 New Kids on the Block Diagram (16 Points)

### 2.1 Part 1

Consider a system described by the following equation, where A and B are constants, X represents the input signal, and Y represents the output signal:

$$y[n] = Ax[n] + Bx[n - 1]$$

Is the system represented by the block diagram below equivalent to the system above for some values of A and B? If yes, enter the specific values of A and B necessary into the boxes below. If this is not possible, enter None in both boxes.

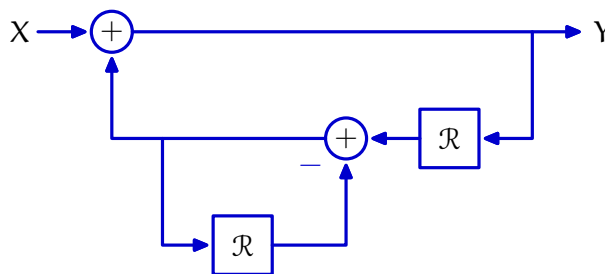

A =

B =

### 2.2 Part 2

Consider a system described by the following equations, where C and D are constants, X represents the input signal, and Y represents the output signal:

$$y[n] = Cx[n] + Dw[nn]$$

$$w[n] = y[n - 1] + w[n - 1]$$

Is the system represented by the block diagram below equivalent to the system above for some values of C and D? If yes, enter the specific values of C and D necessary into the boxes below. If this is not possible, enter None in both boxes.

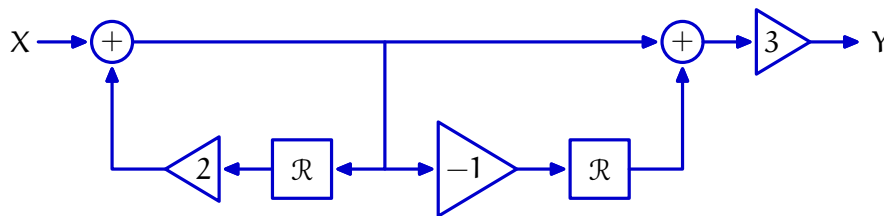

C =

D =

### 2.3 Part 3

What is the system functional for the system described by the following block diagram?

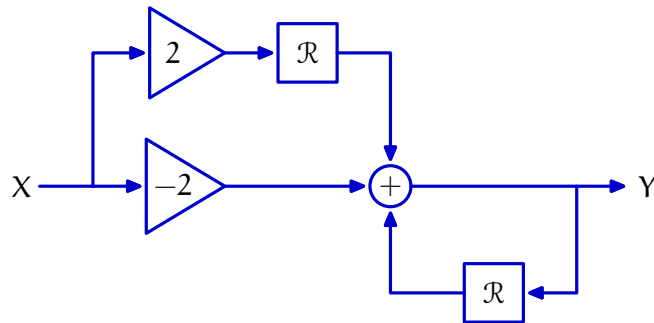

$$\frac{Y}{X} =$$

### 2.4 Part 4

What are the poles of the system described by the block diagram below?

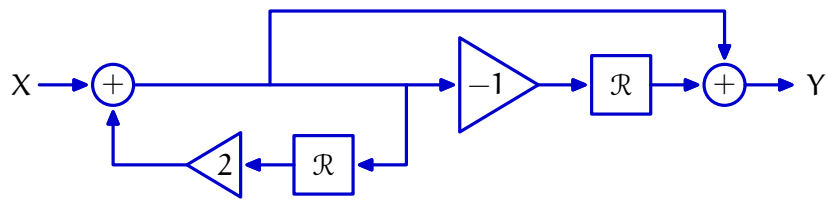

Poles:

### 3 Red and Green Delays (16 Points)

Irving is interested to make some probabilistic estimates about his morning commute. Over time, he builds up the following model regarding the two trains on his commute, each of which can be either on time or delayed:

- The probability that both the red line and the green line are on time is  $1/10$ .
- When the red line is on time, the probability of the green line being on time is  $2/3$ .
- When the green line is on time, the probability of the red line being on time is  $2/10$ .

Given this model, answer the following:

1. What is the probability that the green line is delayed?

2. What is the probability that the red line is delayed?

3. What is the probability that both lines are delayed?

4. What is the probability that Irving experiences a delay on *at least one* of the two trains in the morning?

5. If Irving's red line train is delayed, what is the probability that his green line train is on time?

## 4 Peaches and Pairs (16 Points)

For each pair of circuits below, express constraints on the values of the components in the circuits that would make the two circuits equivalent to one another (in terms of voltage/current relationship at the port labeled  $V$ ).

Please solve for numeric values exactly, but you may use  $+$  and  $\parallel$  in your answers to represent series and parallel combinations of symbolically-specified resistors, respectively, rather than expanding those expressions out fully.

You may assume that all op-amps are ideal, and you may ignore power supply limitations.

### 4.1 Pair 1

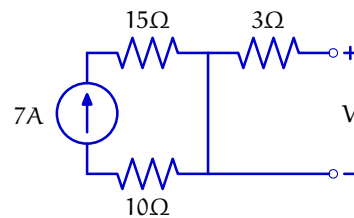
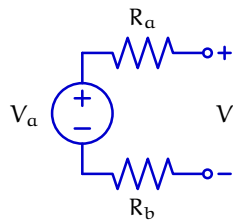



4.2 Pair 2

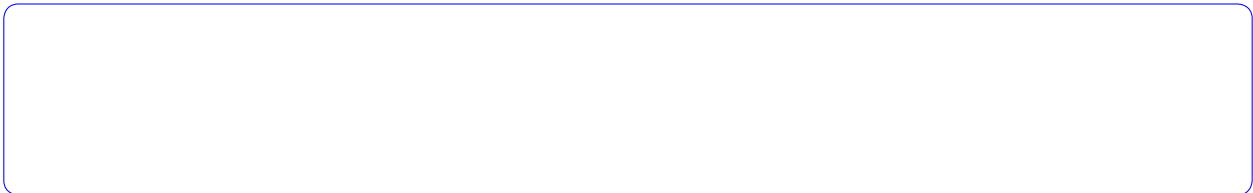
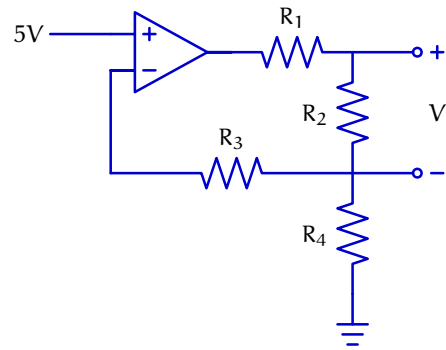
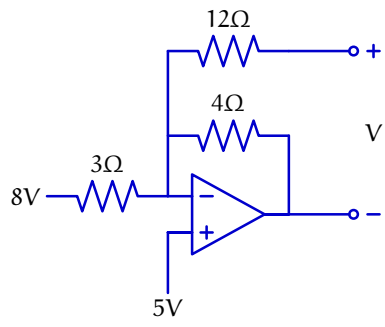



## 5 Bulb Brightness (24 Points)

In this problem, we will consider circuits that are designed to power two different light bulbs simultaneously. We will assume that our light bulbs can be modeled as  $5\Omega$  resistors, and that the brightness of each is proportional to the voltage drop across it.

For example, if the bulbs are hooked up as follows, the voltage drop across each bulb will always be  $5V$ , and so their brightnesses will always be equal:

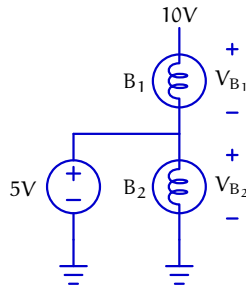

Now, we wish to use a  $10k\Omega$  potentiometer to provide the bulbs with a variable voltage, as we did in lab.

Recall that a potentiometer is a three-terminal device that can be modeled as two separate resistors, whose values depend on  $\alpha$  (the normalized angle of the pot's mechanical shaft):

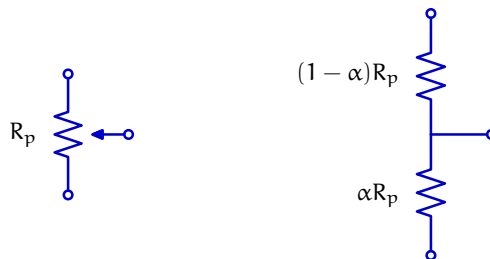

For each of the circuits on the following page, sketch a graph of the voltage drops across  $B_1$  and  $B_2$  versus  $\alpha$  (note that you do not have to solve for this relationship exactly).

**For this question, assume that all op-amps are ideal and are powered with  $+10V$  and  $0V$ .**

**5.1 Circuit 1**

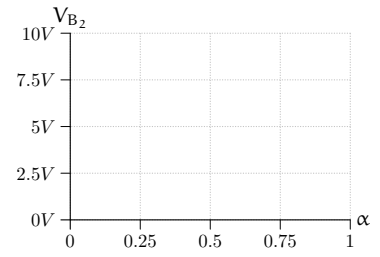
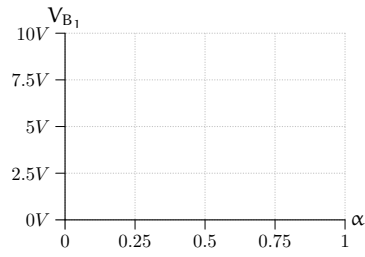
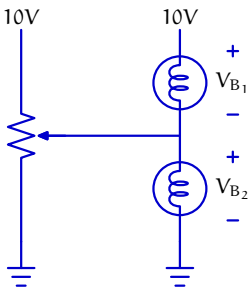

**5.2 Circuit 2**

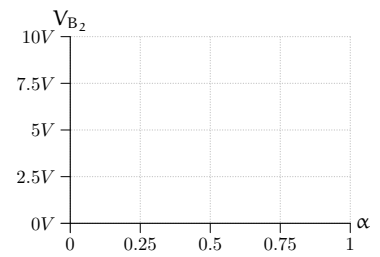
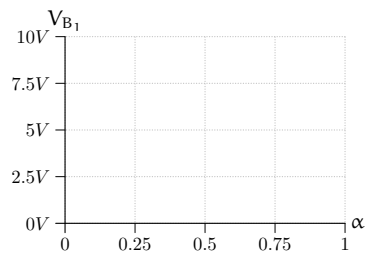
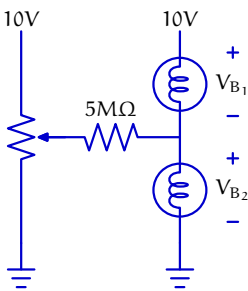

**5.3 Circuit 3**

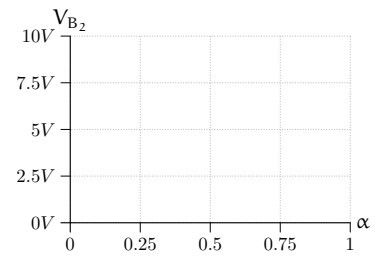
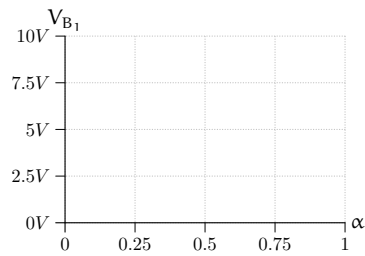
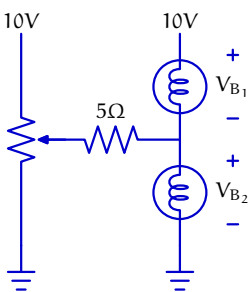

### 5.4 Circuit 4

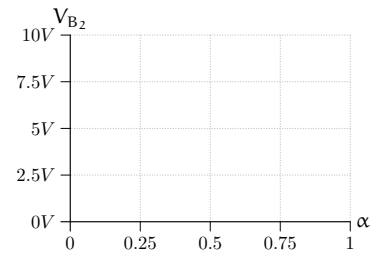
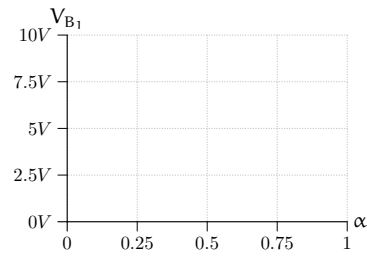
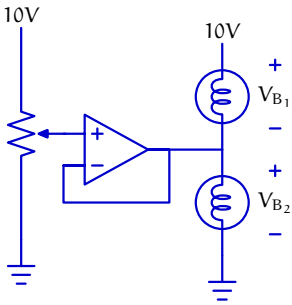

### 5.5 Circuit 5

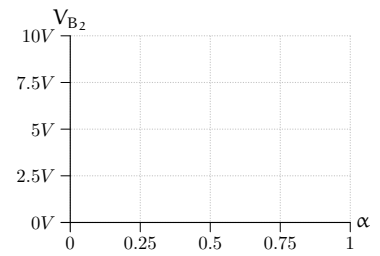
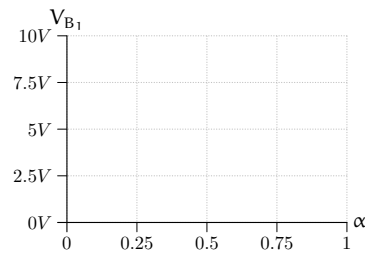
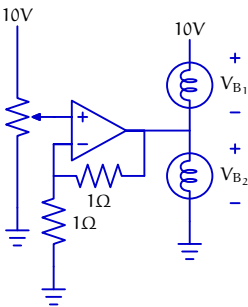

### 5.6 Circuit 6

