

6.01 Midterm 2

Spring 2019

Name:

Kerberos (Athena) name:

Please WAIT until we tell you to begin.

During the exam, you may refer to any written or printed paper material.
You may NOT use any electronic devices (including calculators, phones, etc).

If you have questions, please **come to us at the front** to ask them.

Enter all answers in the boxes provided.

Extra work may be taken into account when assigning partial credit,
but only work on pages with QR codes will be considered.

Question 1: 20 Points

Question 2: 15 Points

Question 3: 15 Points

Question 4: 20 Points

Question 5: 14 Points

Total: 84 Points

1 On a Monday I am Waiting (20 Points)

For each of the sets of components below, use the components to create a circuit that has the specified value somewhere in it. Clearly label the values of all sources and resistors, as well as the specified value.

Note that there may be multiple correct solutions, and that you do not need to use all of the components for any given question.

1.1 Set 1

Set 1 contains two 1Ω resistors, two 4Ω resistors, and one $9V$ voltage source.

Use these components to make a current of $3A$. Label this value clearly in your schematic below.

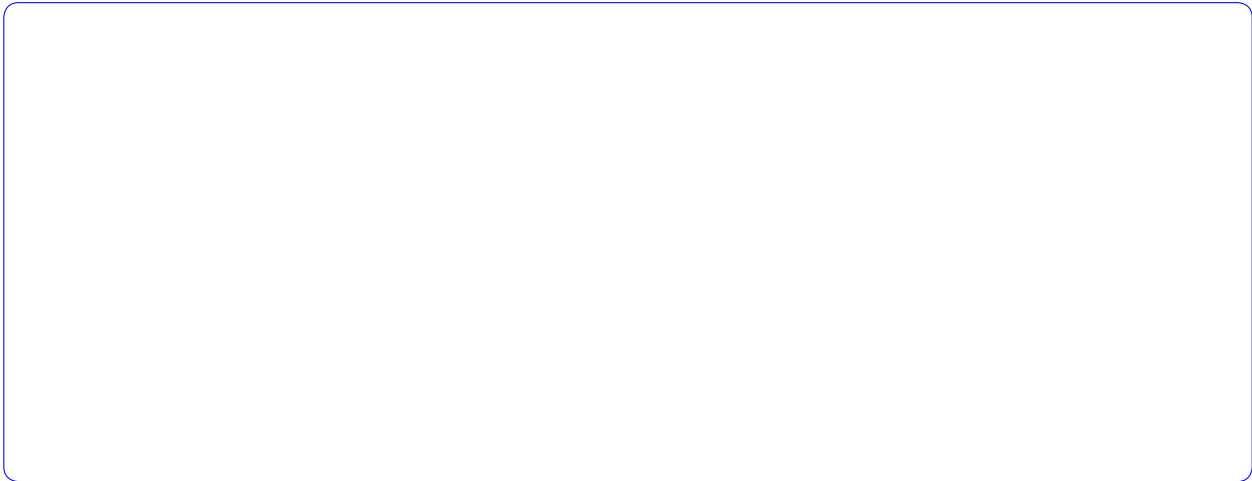

1.2 Set 2

Set 2 contains two $1k\Omega$ resistors, one $8V$ voltage source, and one $2V$ voltage source.

Use these components to make a potential difference of $5V$. Label this value clearly in your schematic below.

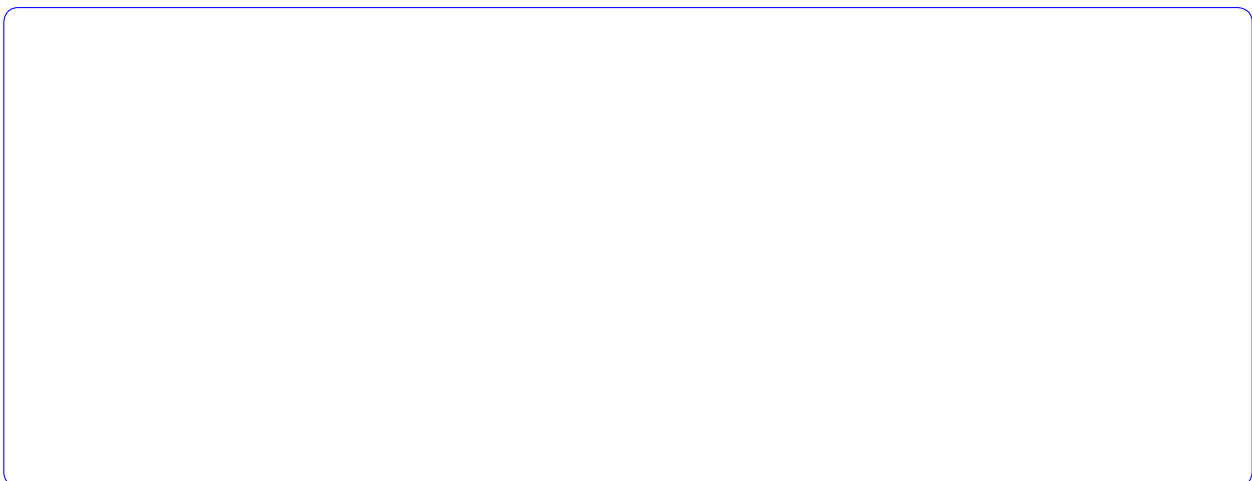

1.3 Set 3

Set 3 contains one 12V voltage source, one ideal op-amp, three 1Ω resistors, and three 2Ω resistors. Use these components to make a potential difference of 16V. Label this value clearly in your schematic below.

You may assume that the op-amp is powered by a separate power supply that is large enough that you do not have to worry about output limitations of the op-amp.

**1.4 Set 4**

Set 4 contains one 3A current source, one 7A current source, three ideal op-amps, and six 1Ω resistors.

Use these components to make a potential difference of 5V. Label this value clearly in your schematic below.

You may assume that the op-amps are powered by a separate power supply that is large enough that you do not have to worry about output limitations of the op-amps.

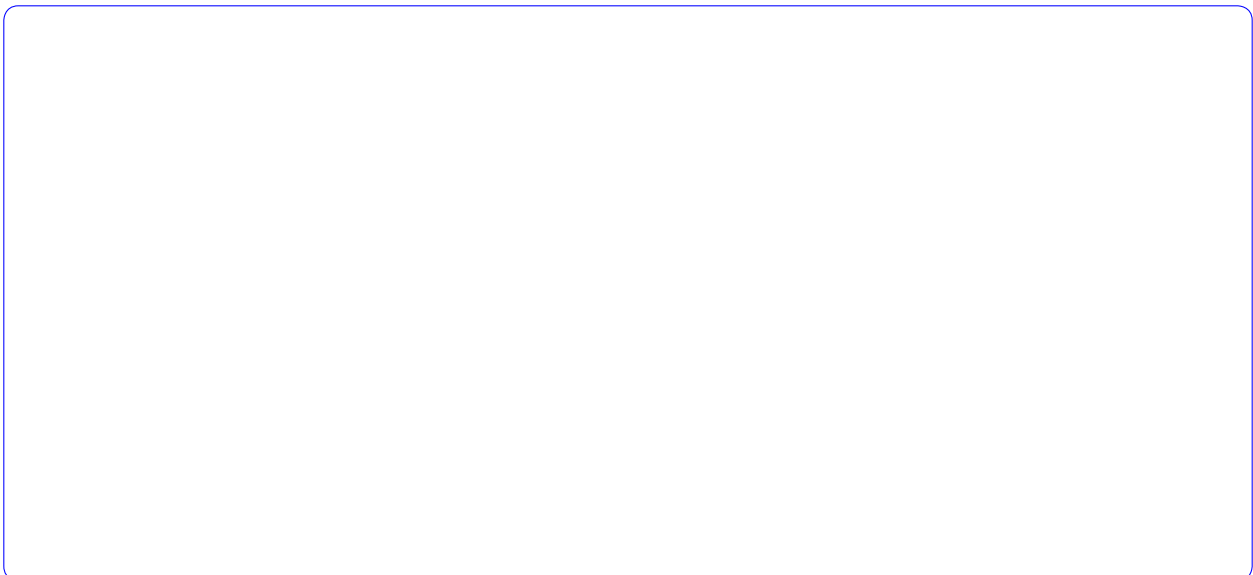

2 Real Differences (15 Points)

Consider a system \mathcal{H} , which transforms an input signal X into an output signal Y :

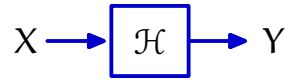

Suppose the input signal is a unit sample:

$$x[n] = \delta[n] = \begin{cases} 1 & \text{if } n = 0 \\ 0 & \text{otherwise} \end{cases}$$

and for that input, the samples of the output response signal are:

$$y[n] = \begin{cases} (-2)^n & \text{if } n \geq 0 \\ 0 & \text{otherwise} \end{cases}$$

2.1 Block diagram

Which of the following block diagrams is an equivalent representation of the system \mathcal{H} ?

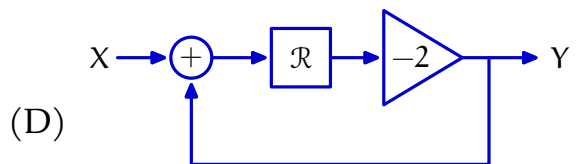
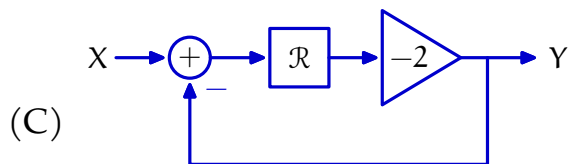
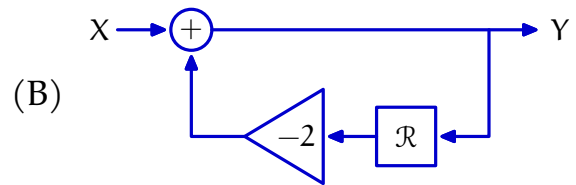
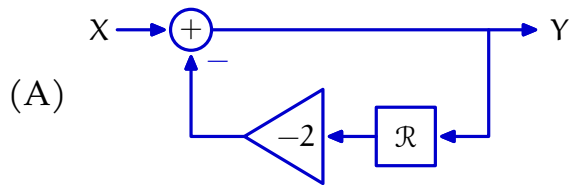

Choose exactly one (A, B, C, or D):

2.2 Composition

Suppose we have another system \mathcal{F} , which takes as input Y and gives as output Z :

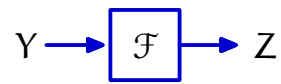

You are given that \mathcal{F} 's system functional is:

$$\frac{Z}{Y} = \frac{1}{1 - \frac{1}{2}\mathcal{R}}$$

Compose the systems \mathcal{H} (from the previous parts) and \mathcal{F} to produce a new system which takes X as input, and outputs Z :

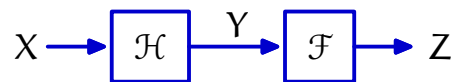

Which of the block diagrams on the facing page (page 5) could be equivalent to this new system (assuming the gains were correctly chosen)?

Choose **one or more of** (1, 2, 3, 4, 5):

2.3 Pole Problems

Ben Bitdiddle has a different system with poles at 10, 1, and 0.1. For that system, he reasons that the unit sample response must be a constant value for all $n \geq 0$, since $10^n \cdot 0.1^n \cdot 1^n = 1$ for all n .

Is Ben's reasoning correct? (Yes/No):

Briefly explain (1-2 sentences):

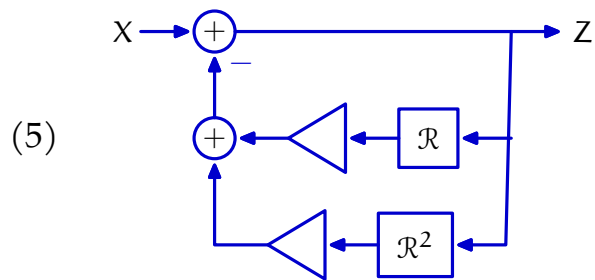
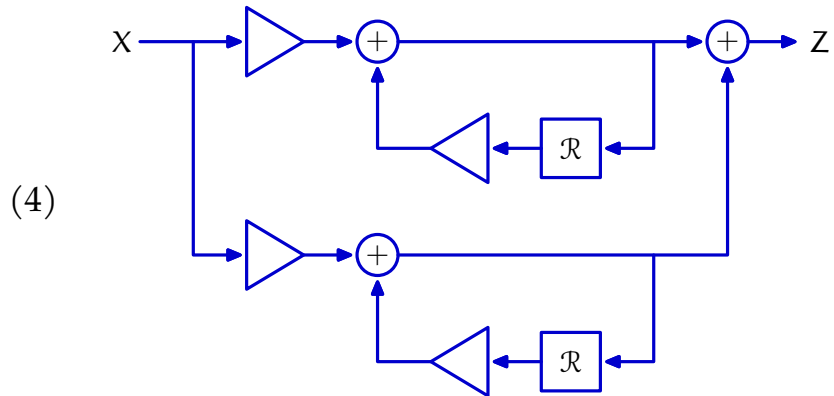
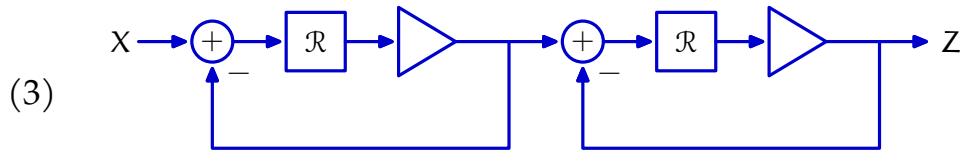
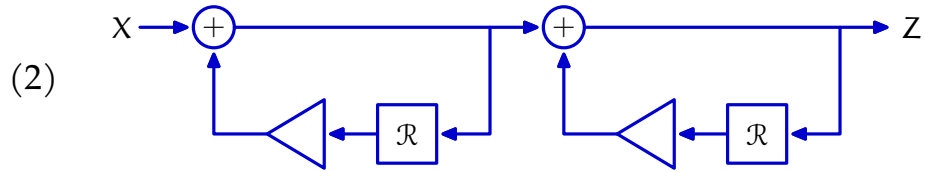
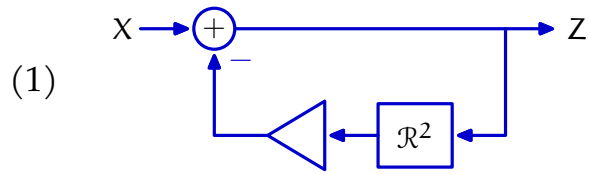

3 Parallelism (15 Points)

In this problem, we will consider a Python program to find instances of parallel combinations of components in a resistor network. We will represent resistors with the following class:

```
class Resistor:
    def __init__(self, resistance, node1, node2):
        self.r = resistance
        self.n1 = node1
        self.n2 = node2
```

For example, the following represents a resistor with resistance 500Ω , whose terminals are connected to nodes "e1" and "e2": `Resistor(500, "e1", "e2")`

A resistive network will be represented by a list of these objects.

3.1 By Hand

Consider the resistor network represented by the following list:

```
circuit = [Resistor(5, 'n1', 'n2'),
           Resistor(2, 'n1', 'n3'),
           Resistor(3, 'n3', 'n4'),
           Resistor(7, 'n3', 'n2'),
           Resistor(8, 'n4', 'n3')]
```

In the box below, draw a schematic representing this circuit:

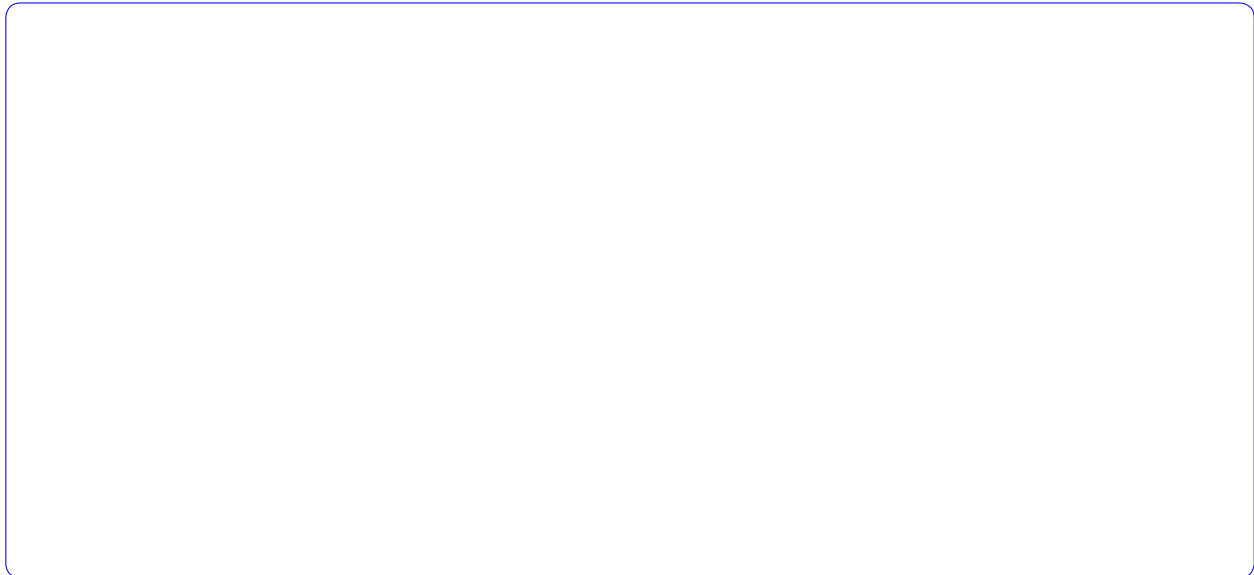

3.2 Python

On the following pages, define the following functions:

- `parallel_val(val1, val2)` should take two numbers as input, and should return a single number representing the equivalent resistance of the parallel combination of those resistances.
- `find_parallel(resistors)` should take a list of `Resistor` instances as input. It should return a list of tuples `(r1, r2)` representing the parallel. Each tuple should contain two resistors that are connected in parallel within the given network. If no parallel combinations exist, it should return an empty list.

```
def parallel_val(val1, val2):  
    # your code here
```



```
def find_parallel(resistors):  
    # your code here
```

4 Line Rider (20 Points)

For each of the circuits below, sketch the curve representing the relationship between i and v .

4.1 Circuit 1

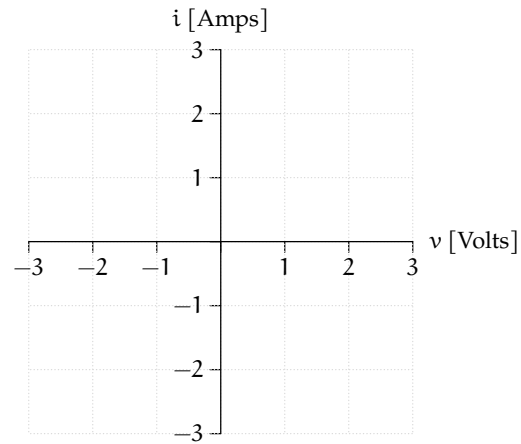
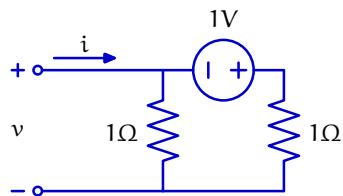

4.2 Circuit 2

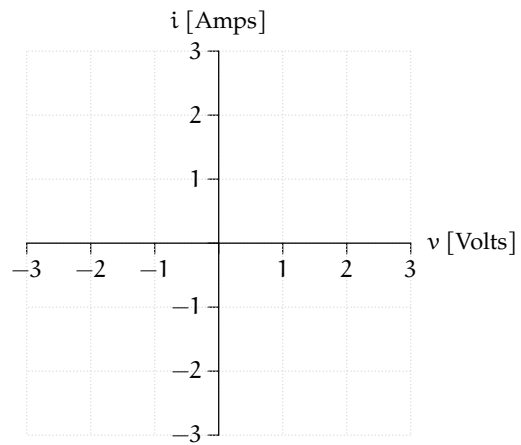
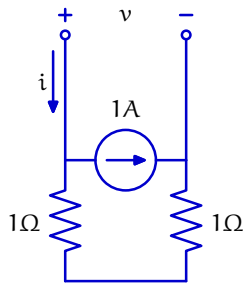

4.3 Circuit 3

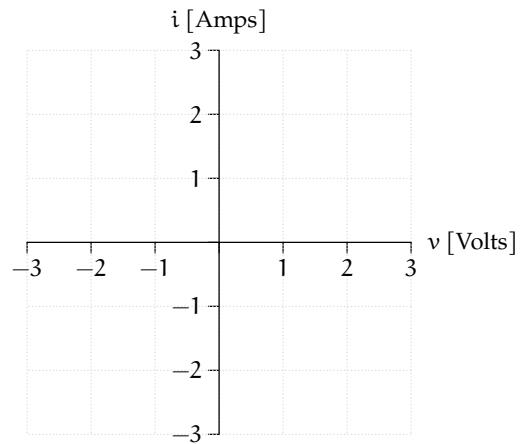
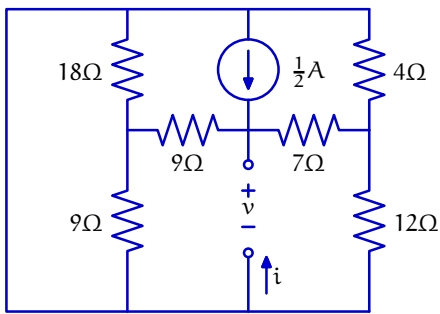

4.4 Circuit 4

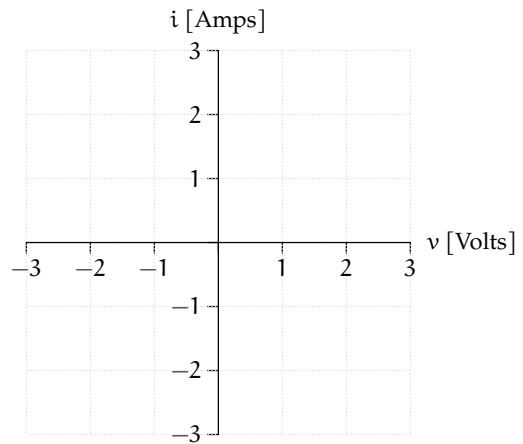
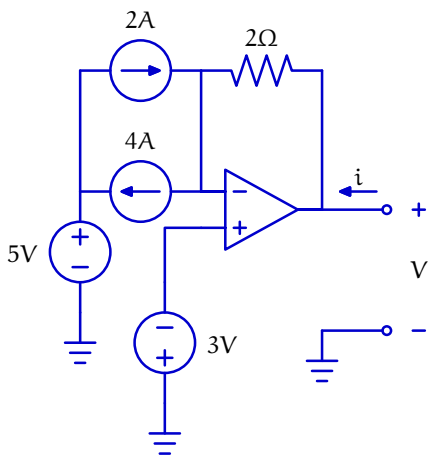

5 Color Me Maybe (14 Points)

Carly Rae Jepsen wants to paint her living room. Being on a limited budget, she is very interested to hear about Random Paints, Inc. that sells and ships cans of paint to a customer for a low low price. For just \$2, she can get one can of paint. Random Paints, Inc. is able to sell for such a low price because they only ship surplus paints, but the customer is never sure exactly what color or what size container of paint they will get (but they do indeed always get a can of paint!).

The possible colors that the customer will get are red, green, or blue. The possible container sizes are "medium" or "large".

The following table represents the joint distribution over colors and sizes:

		Pr(color, size)		
		red	green	blue
medium	a	b	c	
	large	x	y	z

Answer the following questions in terms of the joint probabilities a , b , c , x , y , and z .

1. What is the probability of receiving a medium can of paint?

2. What is the probability of receiving either green or blue paint?

3. If a medium can of paint arrives, what is the probability the paint color will be green?

4. What is the probability of receiving a large can of paint, given that the paint was not blue?

5. What is the probability of receiving a medium can of paint, given that the paint was red?

Based on historical data (coming from many customer comments posted online), Carly Rae learns the following:

- The probability of getting red paint is 0.3
- If a large can arrives, the probability that the color of paint is not red is 0.5
- The probability of getting a medium can is 0.6
- The probability of getting a medium can of green paint is 0.38

Given this information, solve for the joint probabilities in the table. Enter a single number in each box below (fractions are okay!), or enter NEI (for "Not Enough Information") if there is not enough information to solve for the given quantity.

$a =$

$b =$

$c =$

$x =$

$y =$

$z =$

