

6.01 Midterm 1

Spring 2019

Name:

Answers

Kerberos (Athena) name:

Please WAIT until we tell you to begin.

During the exam, you may refer to any written or printed paper material.
You may NOT use any electronic devices (including calculators, phones, etc).

If you have questions, please **come to us at the front** to ask them.

Enter all answers in the boxes provided.

Extra work may be taken into account when assigning partial credit,
but only work on pages with QR codes will be considered.

Question 1: 23 Points

Question 2: 18 Points

Question 3: 18 Points

Question 4: 16 Points

Question 5: 18 Points

Total: 93 Points

Worksheet (intentionally blank)

1 Cart Blanche (23 Points)

In this problem, we will consider a small cart on a flat surface:



It is possible to move the cart along the surface by applying a force F to the back of the cart. The cart has a mass m (kilograms), and its acceleration a is governed by Newton's Second Law of Motion:

$$F = ma$$

We will start by building a discrete-time model of this system. Complete the sketch of the block diagram of this system below, using finitely-many gains, delays, and/or adders/subtractors. Assume that the cart's acceleration is set at the start of each timestep based on the current force on the cart, and that the cart maintains that acceleration for the full timestep. Let the signals F , A , and V represent the force applied to the cart in Newtons, the cart's acceleration in meters/sec², and the cart's velocity in meters/sec, respectively, and let T be the length of one timestep in seconds.

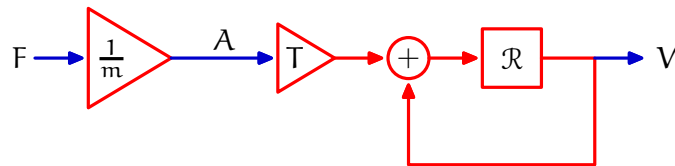

1.1 Friction

We can model friction in the system by adding a feedback loop as shown below. Here, the net force acting on the cart is the sum of an input force F_i and a force from friction, which is proportional to the cart's velocity.

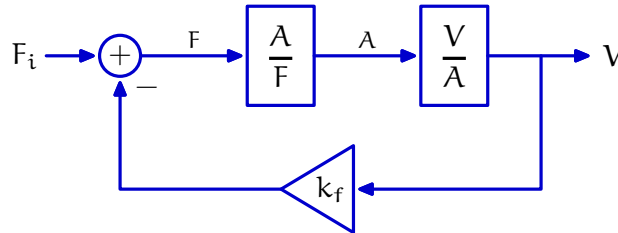

What are the units of k_f ?

$$\frac{\text{N}}{\frac{\text{m}}{\text{s}}} = \frac{\text{kg}}{\text{s}}$$

Solving, we find that the system functional of this entire system is:

$$\frac{V}{F_i} = \frac{T\mathcal{R}}{m - m\mathcal{R} + k_f T\mathcal{R}}$$

How many poles does this system have?

1

What are the poles of this system?

$$1 - \frac{k_f T}{m}$$

1.1.1 Slowing Down

Assume that at time 0, a cart with a mass of 2kg is moving at a velocity of 20m/s. If the length of a timestep is $T = 0.1\text{s}$ and we are running in a world where $k_f = 8$, approximately how long will it take for the cart to decelerate to 0.2m/s if no force other than friction is applied?

You do not need to simplify your answer completely; your answer may include numbers, multiplication, n , \sin , \cos , \tan , \log , and/or $\sqrt{\cdot}$.

$$\frac{\log_{0.6} 0.01}{10}$$

seconds

1.2 Position

Finally, we would like to expand our model to include the cart's position P (meters). Assume that the cart's velocity is set at the beginning of each timestep, and that it maintains a constant velocity for the entire timestep. Complete the block diagram of this system below, using finitely-many gains, delays, and/or adders/subtractors:

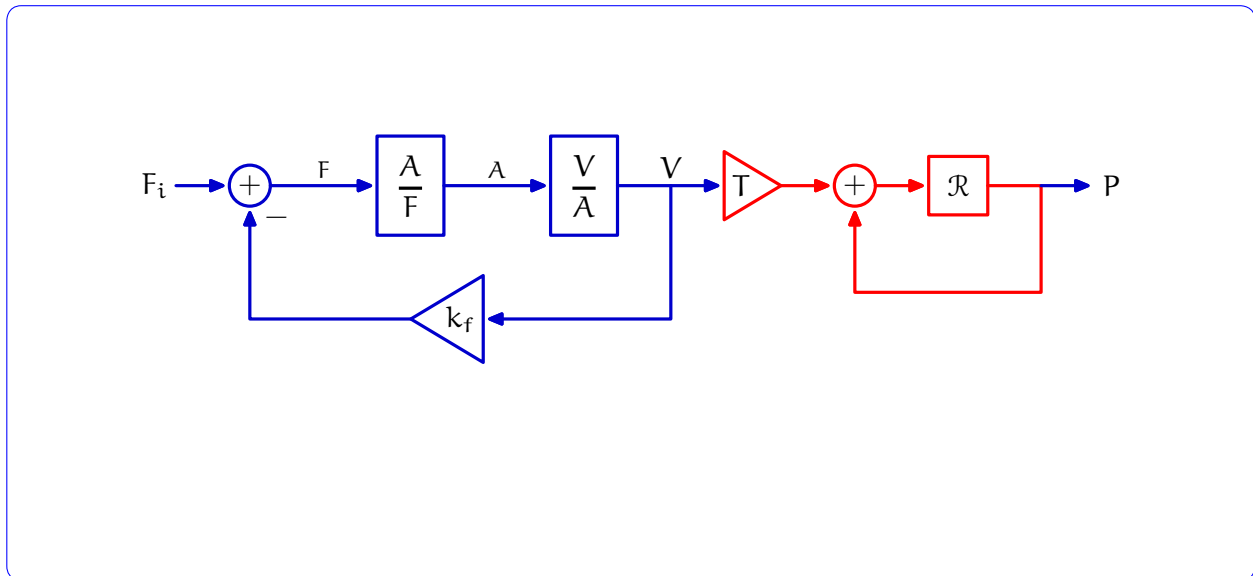

How many poles does this system $\left(\frac{P}{F_i}\right)$ have?

2

What are the poles of this system $\left(\frac{P}{F_i}\right)$?

$1, 1 - \frac{k_f T}{m}$

1.3 Graphs

Assuming that the cart starts at rest and the external force is 1 Newton at time 0, and 0 Newtons on all other timesteps, which of the graphs on the facing page represents each of the following signals? Enter a single number in each box, or enter None if none of the graphs depict that signal. Note that the scales may be different for each of the graphs. Note that some of the graphs may be used more than once, and some may not be used at all.

The external force applied to the cart (F_i):	6
The net force on the cart (F):	11
The cart's acceleration (A):	11
The cart's velocity (V):	0
The cart's position (P):	1
The friction coefficient (k_f):	None

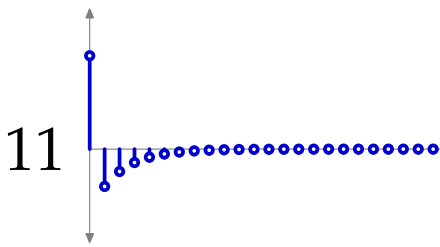
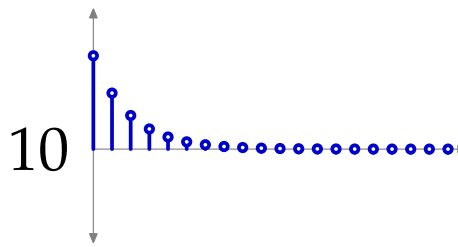
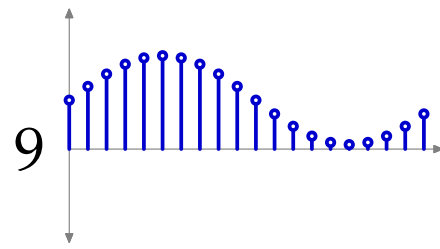
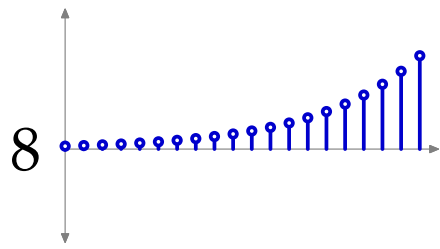
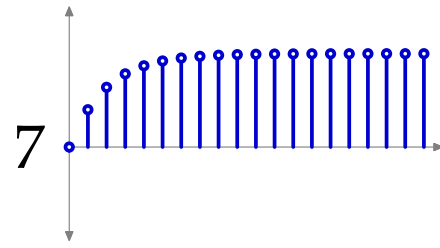
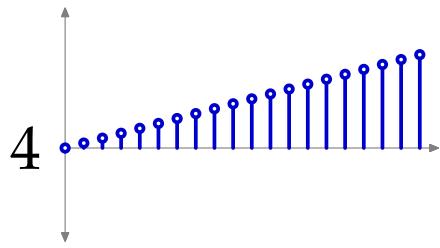
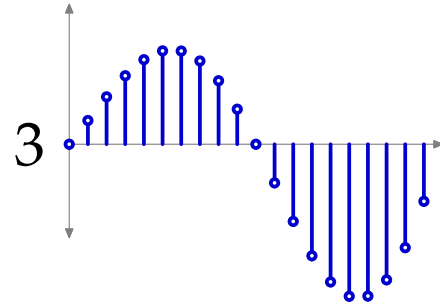
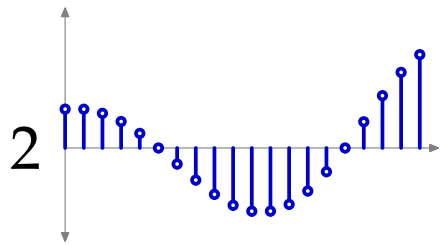
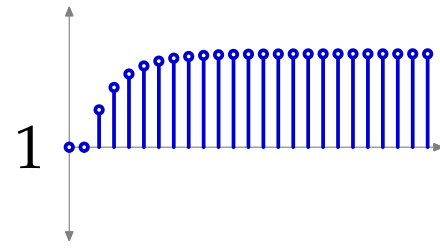
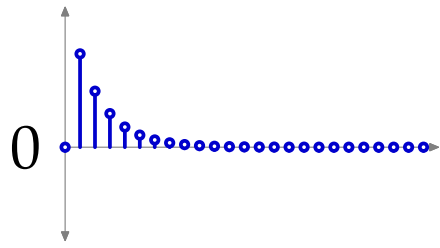

2 Solera (16 Points)

Let \mathcal{H} represent a system that is defined as an instance of the Solera class of systems:

```
class Solera(System):
    def __init__(self):
        self.initial_state = (0, 0, 0)

    def calculate_step(self, state, inp):
        a = (inp + state[0]) / 2
        b = (state[0] + state[1]) / 2
        c = (state[1] + state[2]) / 2
        return ((a, b, c), state[2])
```

Part a.

Let $h[n]$ represent the unit-sample response of the Solera system \mathcal{H} . Determine the first 7 samples of $h[n]$.

$$h[0] =$$

0

$$h[1] =$$

0

$$h[2] =$$

0

$$h[3] =$$

$\frac{1}{8}$

$$h[4] =$$

$\frac{3}{16}$

$$h[5] =$$

$\frac{3}{16}$

$$h[6] =$$

$\frac{5}{32}$

Part b.

What is the system functional of the SoLera system? Enter your answer as a rational polynomial in \mathcal{R} .

$$\mathcal{H} = \frac{Y}{X} = \left(\frac{\frac{1}{2}\mathcal{R}}{1 - \frac{1}{2}\mathcal{R}} \right)^3 = \frac{\frac{1}{8}\mathcal{R}^3}{1 - \frac{3}{2}\mathcal{R} + \frac{3}{4}\mathcal{R}^2 - \frac{1}{8}\mathcal{R}^3}$$

3 All Systems Go! (18 Points)

Below, you are given a piece of the unit sample response of several different LTI systems, when started from rest. For each, clearly mark with an \times the location(s) of that system's pole(s) in the complex plane.

3.1 System 1

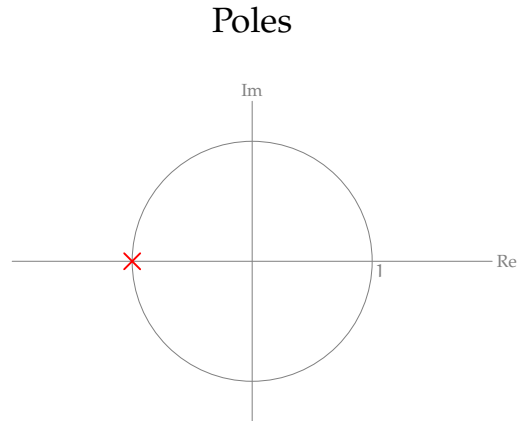
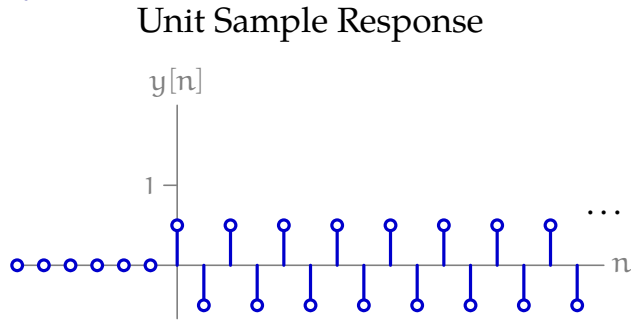

3.2 System 2

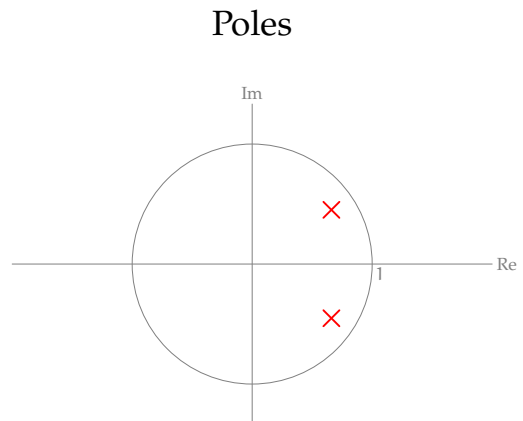
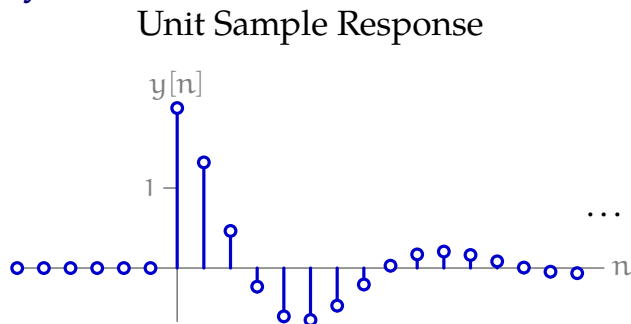

3.3 System 3

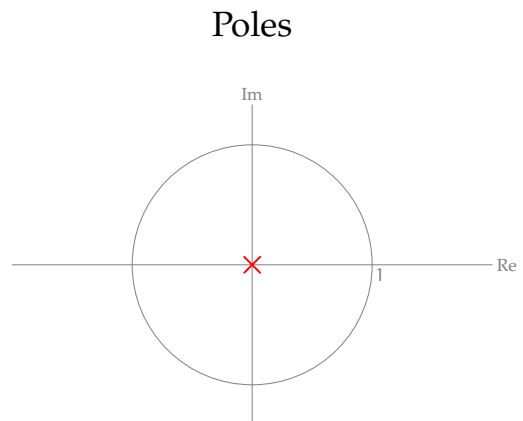
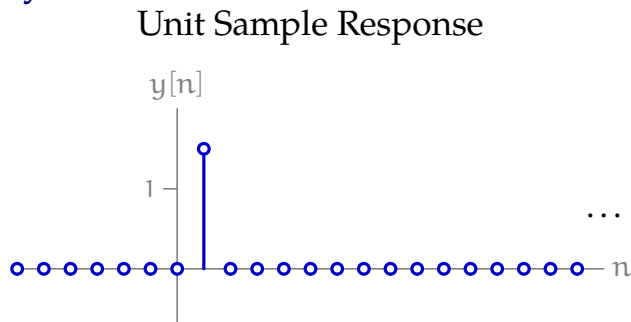

3.4 System 4

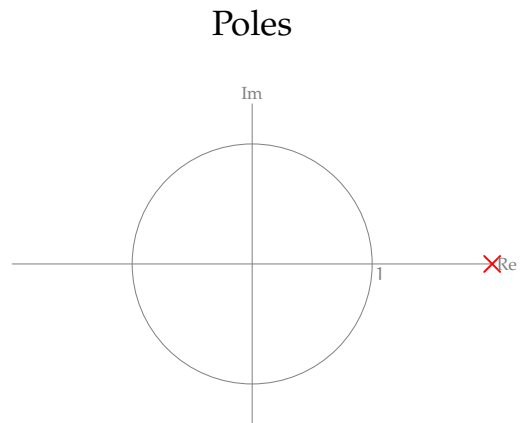
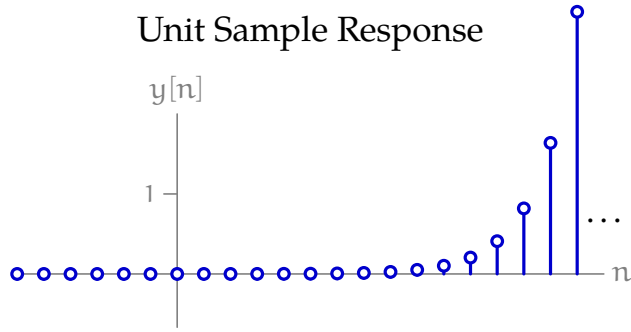

3.5 System 5

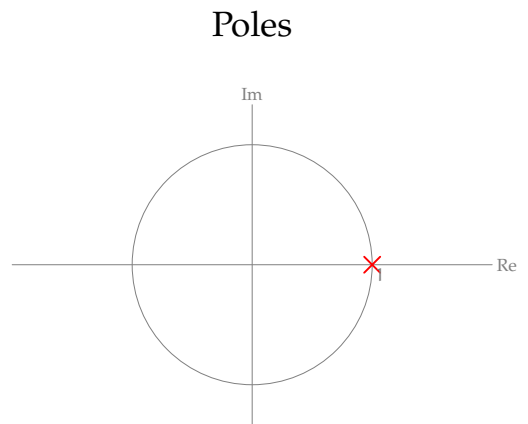
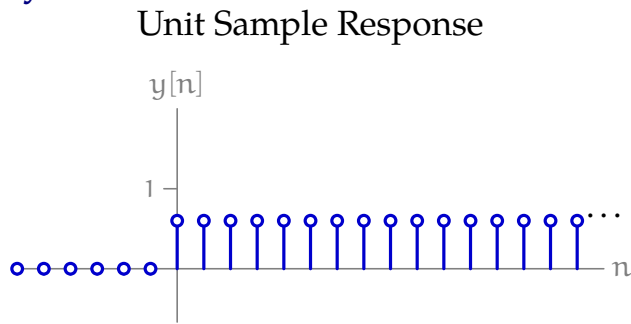

3.6 System 6

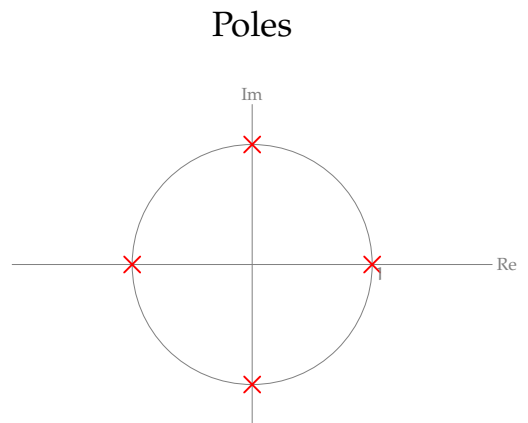
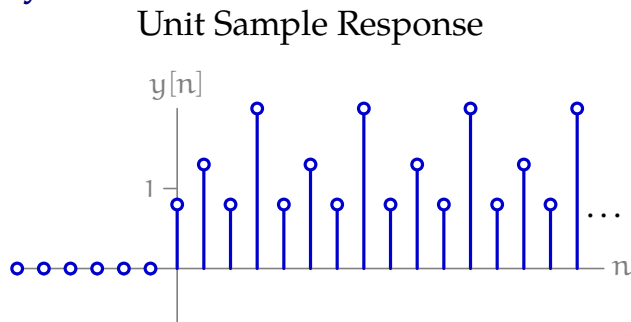

4 Solving Circuits (12 Points)

Ben Bitdiddle is trying his hand at solving circuits. For each of the circuits below, Ben has written out his reasoning, broken down into a number of steps. For each circuit:

- if Ben made a mistake, write the number of the step where Ben made his *first* mistake in that question, and write a brief explanation of why it was a mistake.
- if Ben solved the circuit correctly, write None in the box, and leave the explanation empty.

Note that $x||y$ represents the parallel combination of resistors x and y .

4.1 Circuit 1

In the first circuit, Ben is asked to solve for the voltage V_1 in the circuit below:

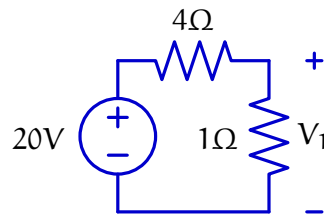

Ben takes the following steps when solving this circuit:

1. Because the 20V source is connected to the 4Ω resistor, Ben knows that the current flowing through that resistor must be $20V/4\Omega = 5A$.
2. By KCL, that same current must be flowing through the 1Ω resistor.
3. 5A through the 1Ω resistor means that the voltage drop across the resistor must be $5A \cdot 1\Omega = 5V$.
4. The voltage drop across the 1Ω resistor is exactly the V_1 Ben wanted to compute, so $V_1 = 5V$.

First mistake, if any:

1

Brief Explanation (1-2 Sentences):

The 20V drop actually occurs across the *series combination* of 4Ω and 1Ω.
So the current flowing through the circuit is actually $\frac{20V}{5\Omega} = 4A$.

4.2 Circuit 2

Ben is asked to solve for the voltage V_2 in the circuit below:

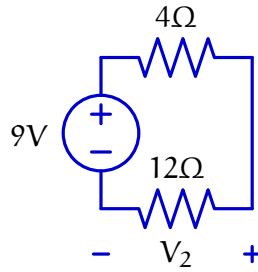

Ben takes the following steps when solving this circuit:

1. Ben notes that the two resistors are connected in parallel and decides to replace them with a single equivalent resistor whose resistance is $4\Omega \parallel 12\Omega = 3\Omega$.
2. The current through the combination is $9V/3\Omega = 3A$.
3. Re-expanding that combination, the current flowing through each resistor must be $3A$.
4. V_2 is the drop across the 2Ω resistor. Because $3A$ is flowing through it, $V_2 = 2\Omega \cdot 3A = 6V$.

First mistake:

1

Brief Explanation (1-2 Sentences):

The two resistors are connected in series, not in parallel.

4.3 Circuit 3

Ben is asked to solve for the voltage V_3 in the circuit below:

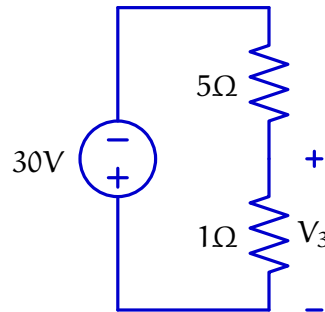

Ben takes the following steps when solving this circuit:

1. Ben notes that the two resistors are connected in series and decides to replace them with a single equivalent resistor whose resistance is $5\Omega + 1\Omega = 6\Omega$.
2. The current through the combination is $30V/6\Omega = 5A$.
3. Re-expanding that combination, the current flowing through each resistor must be $5A$.
4. V_3 is the drop across the 1Ω resistor. Because $5A$ is flowing through it, $V_3 = 1\Omega \cdot 5A = 5V$.

First mistake:

4

Brief Explanation (1-2 Sentences):

Ben forgot to take directionality into account. Because current is flowing *up* through the 1Ω resistor, $V_3 = -5V$.

4.4 Circuit 4

Ben is asked to solve for the voltage V_4 in the circuit below:

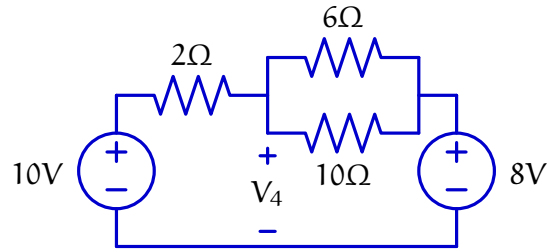

Ben takes the following steps when solving this circuit:

1. Ben notes that there is a 2V drop across the total resistance on the top, which consists of the 2Ω resistor in series with the parallel combination of 6Ω and 10Ω .
2. The equivalent resistance of the parallel combination of 6Ω and 10Ω is $6\Omega \parallel 10\Omega = 8\Omega$.
3. The total resistance is, therefore, $2\Omega + 8\Omega = 10\Omega$.
4. By Ohm's Law, the total current is $2V/10\Omega = 0.2A$, flowing left-to-right.
5. The voltage drop across the parallel combination, then, is $0.2A \cdot 8\Omega = 1.6V$.
6. The total voltage drop V_4 is $8V + 1.6V = 9.6V$.

First mistake:

2

Brief Explanation (1-2 Sentences):

The parallel combination of 6Ω and 10Ω must have a resistance that is less than 6Ω , so it cannot possibly be 8Ω .

5 System Design (18 Points)

Consider an LTI system whose output, in response to a unit sample input, is given by:

$$y[n] = \begin{cases} 0 & \text{if } n < 0 \\ 7 & \text{if } n \geq 0 \text{ and } n \text{ is even} \\ 8 & \text{if } n \geq 0 \text{ and } n \text{ is odd} \end{cases}$$

This relationship is shown in the graph below:

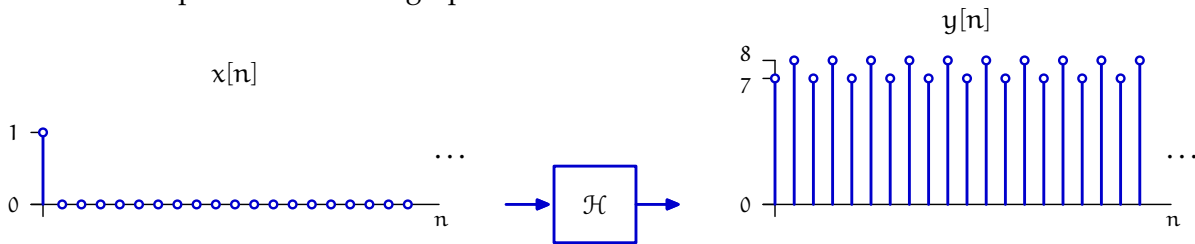

5.1 From Rest

Is it possible to design an LTI system whose unit sample response is $7, 8, 7, 8, 7, 8, \dots$ when started from rest? If so, draw a block diagram for such a system in the box below, using only finitely many delays, gains, and/or adders/subtractors and enter the system's poles in the box below. If not, explain briefly (1-2 sentences) why this is not possible, and enter None in the box for the poles.

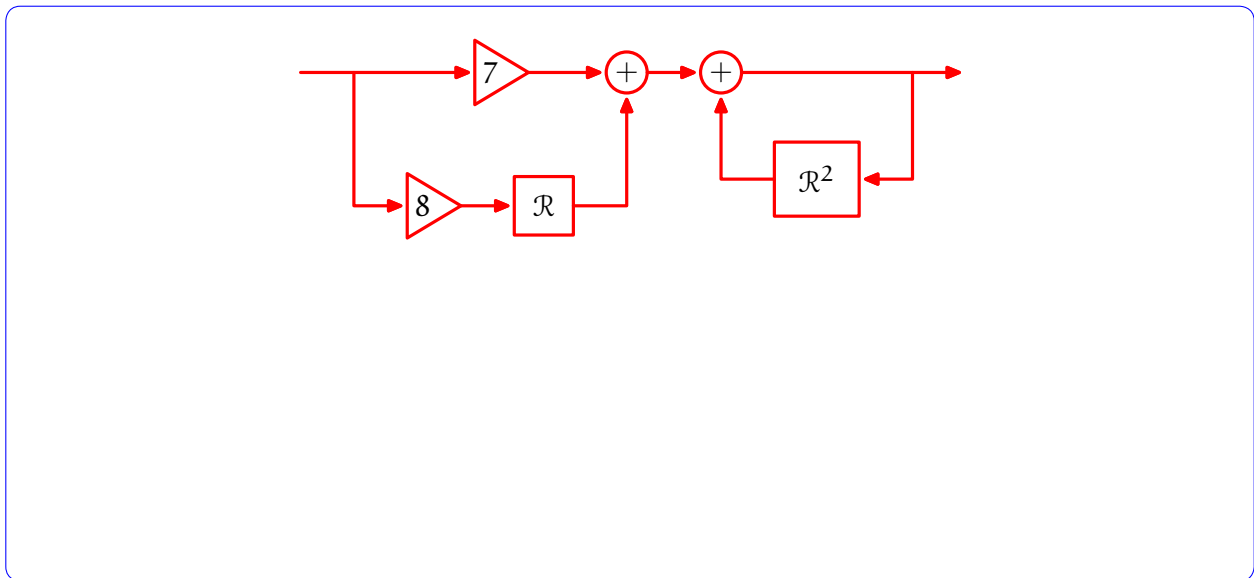

What are the poles of this system?

± 1

5.2 Initial Conditions

Consider the systems below, where $\mathcal{R}(i)$ represents a delay (\mathcal{R}) element initialized so that its first output is i . Is it possible to set the initial conditions on the delay boxes such that these systems will produce the sequence 7, 8, 7, 8, 7, 8, ... in response to a unit sample input? If so, enter the appropriate values for the initial conditions of the delays. If not, enter None in each box.

FeedbackAdd(Gain(1), Cascade($\mathcal{R}(a)$, $\mathcal{R}(b)$))

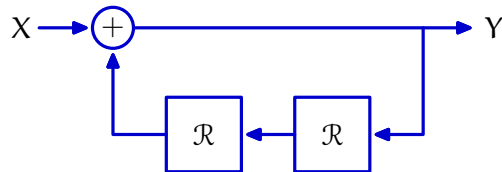

a =

b =

Cascade(FeedbackAdd(Gain(1), Cascade($\mathcal{R}(c)$, Gain(-1))),
FeedbackAdd(Gain(1), $\mathcal{R}(d)$))

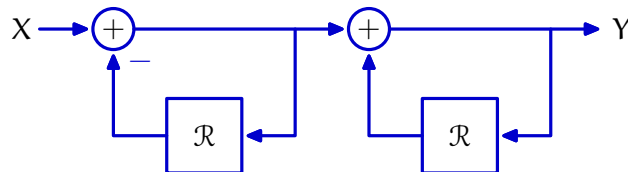

c =

d =

Worksheet (intentionally blank)

Worksheet (intentionally blank)

Worksheet (intentionally blank)

Worksheet (intentionally blank)

Worksheet (intentionally blank)

Worksheet (intentionally blank)

Worksheet (intentionally blank)